



# PHILIPS

**Philips Semiconductors**

---

Interconnectivity

11 January 1999

## **PDIUSBH11A/H12/D12 Evaluation Kit**

### **User's Manual**

---

---

## **PDIUSBH11A/H12/D12 Evaluation Kit: User Manual**

---

---

### **Introduction**

This demo kit uses the PDIUSBH11A (H11A) hub device. The Rev 1.1 Kit precedes the previous release with added functionality and fixes that will be explained in the later part of this application note.

Functionality has been expanded such that the same Hub board can be used to implement a USB Hub with Monitor control system. The USB Monitor Control system, classified under a HID device, is implemented using the embedded function of the H11A. However, the usage of the embedded function of H11A is not exclusive to Monitor Control.

The firmware to control the H11A is backward compatible to the H11 except for some minor changes to fully utilize the new features of the H11A.

### **Features**

This release of the Philips Hub contains the following items:

- Main Philips Hub module
- Add on VGA pass-through Module
- H12/D11-H11A Converter
- Diskette containing the firmware, applet and this document
- USB Cable

---

**PDIUSBH11A/H12/D12 Evaluation Kit: User Manual**

---

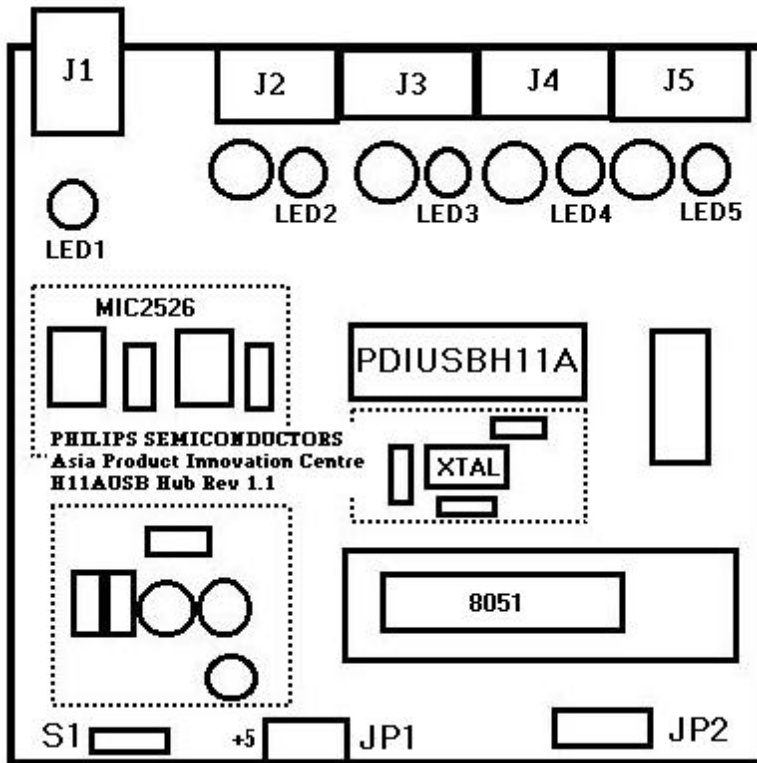
**Main Philips Hub Module**

**1. CONNECTORS**

See table below for the list of connectors

Name	Description
J1	USB Upstream connector
J2	USB Downstream connector, Port 2*
J3	USB Downstream connector, Port 3*
J4	USB Downstream connector, Port 4*
J5	USB Downstream connector, Port 5*
JP1	Power input for self-powered hub
JP2	Expansion bus
S1	Self-powered or bus-powered selection switch.

\*The embedded port of the H11A rest on Port 1, thus all the physical ports are numbered from Port 2 to Port 5.

---



---

## PDIUSBH11A/H12/D12 Evaluation Kit: User Manual

---



---

### 2. Power input (for Self-powered operation)

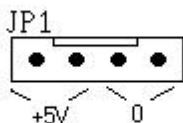

### 3. EXPANSION BUS

JP2

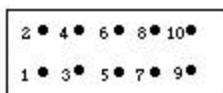

Pin number	Description
1 - GND	Ground
2 - Clkout	Clock output from the H11A
3 - TXD	Transmit Data (from the UART of the micro-controller)
4 - SCL	SCL - to the H11A/H12/D11
5 - SDA	SDA - to the H11A/H12/D11
6 - INT_N	Interrupt from the H11A, active low
7 - SUSPEND	Suspend indicator from the H11A
8 - RXD	Receive Data (from the UART of the micro-controller)
9 - HWSCL	Hardware I2C SCL pin from the micro-controller
10 - HWSDA	Hardware I2C SDA pin from the micro-controller

---



---

## PDIUSBH11A/H12/D12 Evaluation Kit: User Manual

---



---

### 4. INDICATORS

See table below for the list of LED indicators

Name	Description
LED1 (red)	This LED indicates that the downstream ports are powered. Upon proper configuration of the Hub, this LED should be lighted to indicate that the downstream are powered properly.
LED2 (green)	LED 2 indicates that the downstream port 2 is enabled. Whenever downstream port is attached and a proper port detection is done, the downstream port is enabled. If the H11A is in GoodLink™ mode, this LED blinks when traffic is detected via Port 2.
LED3 -5 (green)	same as LED2 except that they correspond to downstream ports 3 to 5 respectively.

There are two DIP sockets for the 51 family of micro-controllers, they are the DIP24 and DIP40. Either one can be used.

DIP24 : 83C748/87C748 (2K EPROM/ROM, 64 RAM)  
83C751/87C751 (2K EPROM/ROM, 64 RAM)

DIP40 : Generic 80C51 (4K ROM)

The above is not an exhausted list. The only consideration would be the ROM size required for the application.

### **VGA Passthrough Module**

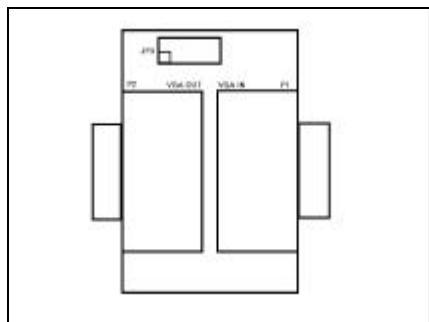

This module acts as a pass through for the normal VGA signals. The wiring for the DDC2B+/2AB monitor control protocol is tapped and routed to the micro-controller via JP2. To use this module, insert it on JP2 of the main board.

---



---

## PDIUSBH11A/H12/D12 Evaluation Kit: User Manual

---



---

### ***H12/D11-H11A Converter***

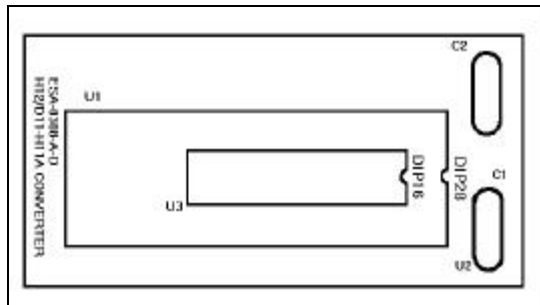

This is a piggyback module on the H11A socket to match the DIP foot-print of PDIUSBH11 and PDIUSBH12.

### **System Configuration**

The demo kit serves as an evaluation and development platform for the PDIUSBH11A, PDIUSBH12 or the PDIUSBH11. Each of the configuration requires the designated firmware on the micro-controller before it can perform its desired function.

#### ***Standalone Hub***

##### *1. H11A (H11A12h.asm)*

Only the main Philips Hub module is required. The module can be either bus-powered or self-powered. To implement a bus-powered hub, S1 needs to be switched to bus-powered. The firmware will auto-detect if it is self or bus powered and supply the appropriate descriptors to the Host.

All four downstream ports are utilized.

The firmware to implement this is H11A12h.asm. H11A12h.hex, the Intel Hex version is also contained on the disk.

---

---

## **PDIUSBH11A/H12/D12 Evaluation Kit: User Manual**

---

---

### ***Monitor Control (Device only)***

#### *2. D11 (D11V11m.asm)*

The main Philips Hub module, the H12/D11-H11A converter and the VGA pass-through module are required. Attach the VGA Pass through module to JP2 of the main board. Route the VGA cable from the Host to the VGA-in of the module, and, connect another VGA cable from the VGA-out to a DDC2B+/2AB compatible Monitor\*.

The principle of operation is as follows. Monitor Control instructions are passed from the host to the USB Monitor Control firmware which deciphers and sends out the corresponding DDC2B+/2AB instruction to control the monitor.

The firmware to implement this is D11V11m.asm. D11V11m.hex, an Intel Hex version is also contained on the disk.

The H11A is software compatible to the D11. Thus development work can also be done on the H11A.

**\*This cannot work if the Monitor does not support DDC2B+/2AB.**

### ***Hub with Monitor Control***

#### *3. H11A (H11A14hm.asm)*

The main Philips Hub module and the VGA pass-through module are required. Attach the VGA Pass through module to JP2 of the main board. Route the VGA cable from the Host to the VGA-in of the module, and, connect another VGA cable from the VGA-out to a DDC2B+/2AB compatible Monitor.

The firmware to implement this is H11A14hm.asm. H11A14hm.hex, an Intel Hex version is also contained on the disk.

---

---

## PDIUSBH11A/H12/D12 Evaluation Kit: User Manual

---

---

### Bugs and Fixes

The improvements done on the USB Hub rev 1.1 are fixes to improve the robustness of the original H11A Hub.

#### 1. Overcurrent Fix

To remove false overcurrent detection due to in-rush current during plugging of downstream port devices, it is recommended that a low-pass configuration as shown below is used.

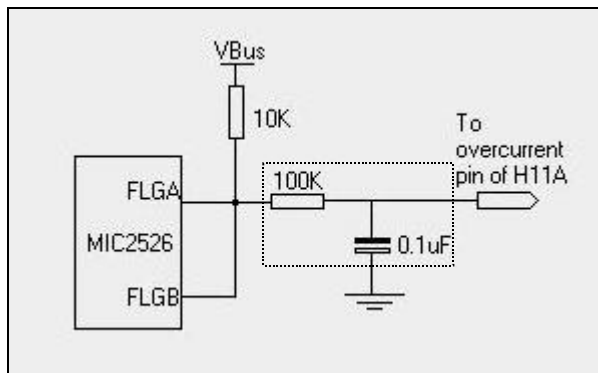

#### 2. Suspend pull-up Fix

The suspend pin from the H11A is an open-drain output, it should be pull-up to a +5V instead of +3.3V.

#### 3. Internal H11A Reset

The Rev 1.1 no longer relies on an RC configuration for it's power on reset. The Reset\_N pin is connected directly to +3.3V.